

Operating Instructions



UNILINE-2048

CCD Monochrome Line Scan Camera

Version E-01 / 12 March 2002

Table of Contents:	Page
1 General	3
2 Accessories	3
3 Description	4
4 Applications Examples	4
5 Adjustment and Calibration	5
6 Sensor Sensitivity	5
7 Lenses and Lens Selection	6
7.1 Lens Selection Table	6
7.2 Setup Graph for Object Widths of 200 to 500 mm	6
7.3 Setup Graph for Object Widths of 500 to 5000 mm	7
7.4 Lens Options	7
8 Camera Control Inputs	8
8.1 EXSYNC (external line start)	8
8.2 MODE (external clock)	8
9 Connecting an Incremental Encoder Directly to the Camera	9
10 Code Switch Tables	10
10.1 Prescaler for the Incremental Encoder	10
10.2 Integration Timer in the Incremental Encoder Mode	10
11 Connector Cable for Incremental Encoder	11
12 Connecting a Frame-Start Initiator Directly to the Camera	11
13 Gain Control and Gamma Function	12
14 Line Scanning Camera Time Graph	13
Controlling the Camera via the Frame Grabber Interface	13
14.2 Free-Running Operation	13
14.3 Integration Time Table for Free-Running Mode	14
15 Connector Pin Assignments	15
15.1 Frame-Start, Supply Power and Incremental Encoder Connector Sockets	15
15.2 Interface, HD 44 Female – Signals Listed in Pairs	15
15.3 Interface, HD 44 Female – Signals Listed According to Pin No., Ascending	16
16 Camera Dimensions and Mounting	17
17 Technical Data	18
18 Maintenance	19
19 Guarantee and Guarantee Conditions	19
20 EC Declaration of Conformity	20

1 General

Mechanical and Electronic Interfaces

The UNILINE-2048 monochrome line scanning camera for industrial image processing is constructed in a simple and durable fashion, and is enclosed in a rugged stainless steel housing.

The cameras can be equipped with an M39x1/26" or an M32.5x0.5 lens mount for Rodenstock CCD lenses. These lenses are distinguished by high resolution and excellent contrast, and are distortion-free to a great extent.

The camera's electronic interfaces are equipped with differential transmitter and receiver chips of the LVDS EIA-644 generation. They are compatible with standardised RS 422 interfaces to a great extent.

2 Accessories

50.20.28	Lens	Rodagon type 28 1:4 / M 32.5 x 0.5
50.20.35	Lens	Rodagon type 35 1:4 / M 39 x 1/26"
50.20.50	Lens	Rogonar type S 50 1:2.8 / M 39 x 1/26"
50.30.28	Adapter tube for lens with 28 mm focal length	
50.30.35	Adapter tube for lens with 35 mm focal length	
50.30.50	Adapter tube for lens with 50 mm focal length	
45.04.05	Connector cable, UNILINE-2048 to frame grabber type: MATROX MeteorII-DIG \ 4 \ L combination interface and data cable, HF shielded 100 Ω surge impedance cable length: 5 m (other lengths upon request)	
50.01.05	Connector cable, UNILINE-2048 to frame grabber type: MATRIX VISION PCimage-SDIG combination interface and data cable, HF shielded 100 Ω surge impedance cable length: 5 m (other lengths upon request)	
50.02.05	Power cable, HF shielded cable length: 5 m (other lengths upon request) prefabricated at camera end, other end blank	
50.03.05	Incremental encoder cable, HF shielded cable length: 5 m (other lengths upon request) prefabricated at camera end, other end blank	
50.04.05	Frame-start cable, HF shielded cable length: 5 m (other lengths upon request) prefabricated at both ends	

3 Description

UNILINE series cameras are compact, rugged industrial line scanning cameras with exceptional performance features. The camera withstands ambient temperatures of up to 45° C, even at maximum data signalling rates. This allows for use in very hot production environments.

A high quality CCD chip with electronic shutter for the reduction of exposure times at the selected scanning rate is at the heart of the camera. The camera's electronics automatically correct temperature related offset-level drift independent of integration time and data signalling rate. Additional offset correction procedures at the PC are thus unnecessary.

As a special feature, process trigger signals such as line start signals generated by an incremental encoder and frame start signals from an initiator can be directly connected to the UNILINE-2048. Encoders are provided with the necessary supply power directly from the camera. This significantly simplifies system wiring, because, as a rule, all of the components are directly at the production line anyway.

The camera only requires one single-supply 12 V power pack, because all of the required operating voltages are generated with appropriate DC-DC transformers inside the camera. Some frame grabbers are equipped with a +12 V auxiliary power supply which is taken from the PC and made available at the interface plug connector. In this case, supply power for the camera can be provided via the interface cable. The 4-pin power socket at the back of the camera is used if no auxiliary power is available from the frame grabber.

4 Applications Examples

The UNILINE-2048 line scanning camera can be used in a wide variety of applications.

- Contactless measuring
- Surface inspection
- Document scanning
- Recognition of printed markings
- Process control

5 Adjustment and Calibration

Adjustment

The camera is adjusted and calibrated at the factory. The sensor chip is aligned to the centre of the optical axis.

The outer mounting and locating surfaces with mounting threads are used as mechanical reference surfaces. This allows for reproducible camera mounting.

6 Sensor Sensitivity

Camera sensitivity is indicated in figure 6-1 up to a wavelength of 1000 nm.

Figure 6-1: **Sensor Sensitivity**

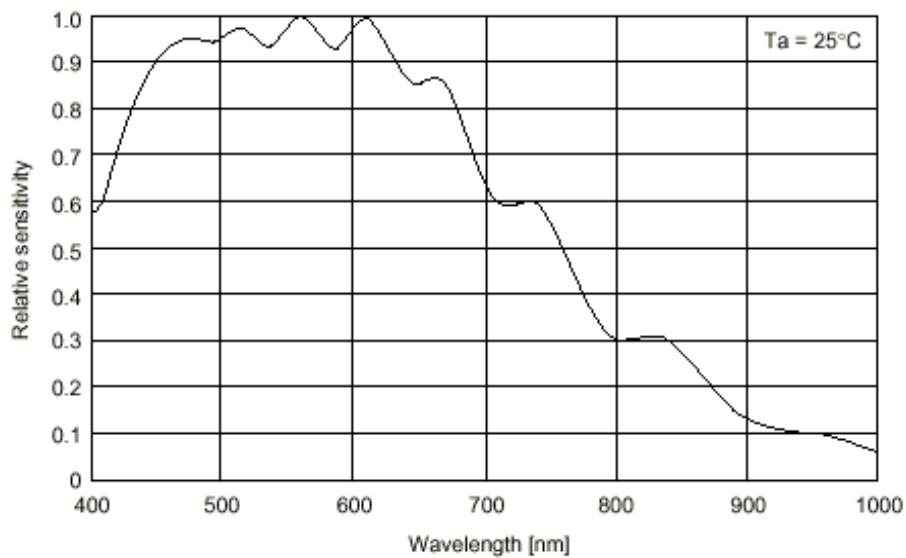

7 Lenses and Lens Selection

7.1 Lens Selection Table

Focal Length mm	RODENSTOCK Lens Type	Tube No.*	Maximum Tube Length L1 / mm	Lens Diameter D / mm	Lens Length L2 / mm
28	Rodagon 28 1:4 M 32.5 x 0.5	28	19.2	40.5	23.3
35	Rodagon 35 1:4 M 39 x 1/26"	35	22.7	50	30.7
50	Rogonar S 50 1:2.8 M 39 x 1/26"	50	38.5	50	31
	M 39 x 1/26" LEICA thread		travel: 10 mm		

An appropriate adapter tube is used with each lens. Please refer to the setup graphs in order to assure correct focal length.

* A tube with adjusting collar is included with the camera. When ordering, please add the appropriate tube number to the order designation: UNILINE -2048-XX

The desired lens must be order separately.

Tubes can also be ordered individually if required (see chapter 2, "Accessories").

7.2 Setup Graph for Object Widths of 200 to 500 mm

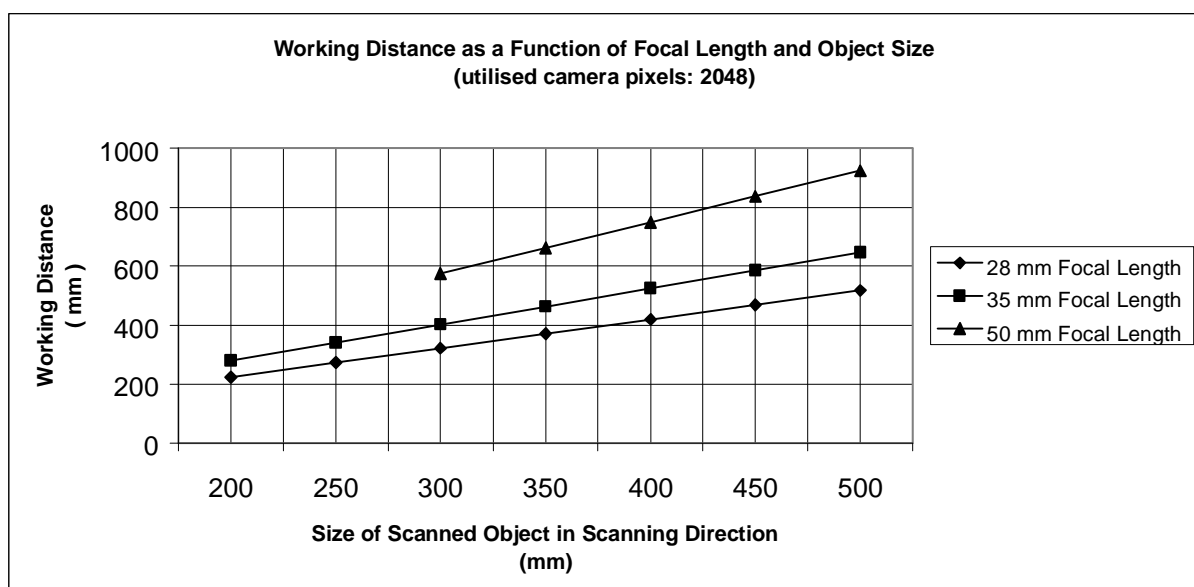

7.3 Setup Graph for Object Widths of 500 to 5000 mm

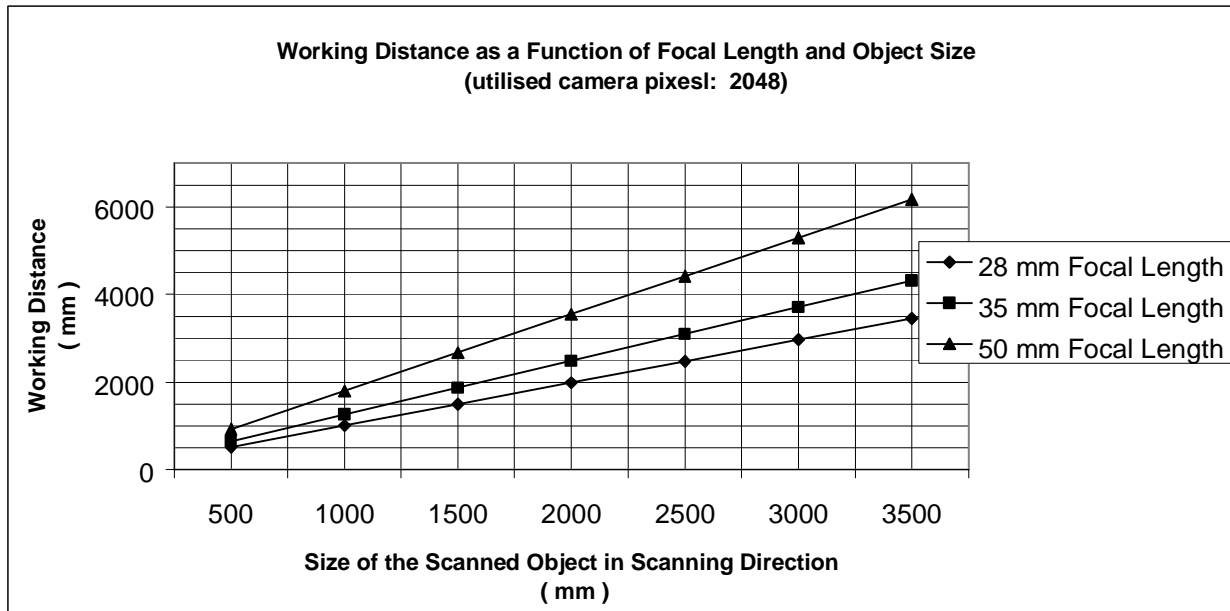

7.4 Lens Options

1. Other Rodenstock lenses can be used as well. Upon request, we would be pleased to provide you with a quotation including the appropriate adapter tube.
2. We can provide you with special tubes for Rodenstock lenses for high resolution applications with image proportions approaching 1:1, or for enlargements.
3. Telecentric lenses can also be used. Please inform us of your requirements so that we can help you select the ideal lens for your application, and provide you with a quotation.

8 Camera Control Inputs

8.1 EXSYNC (external line start)

The line scanning camera can be used in different operating modes: the so-called “free-running mode” and the synchronised mode.

The desired operating mode is selected via the “EXSYNC” input at the interface.

If the EXSYNC input receives no periodical trigger pulses, the camera goes -after a watchdog time of 420 ms- in the free running mode. This means that the line start signals are generated by the camera automatically, the integration time depends upon the BCD code switch position which is selected on the integration timer.

If a dynamic start signal (EXSYNC) is applied, line starts are triggered by the negative edge of the signal. The low state of the signal represents the integration time. In this mode the frame grabber controls the integration time via a programmable software timer. At the end of the integration time the signal turns to high. After an internal camera-specific delay of $64 \times \text{PVAL}$, the line valid signal shifts to high, and the read out phase begins. Where it remains for $2048 \times \text{PVAL}$.

Default Setting: If the EXSYNC input at the interface is not utilised, the camera is automatically operated in the free-running mode!

8.2 MODE (external clock)

The camera can be operated with two master-clock frequencies. Either the MCLK master-clock signal is transmitted via the interface from a frame grabber, or the camera electronics are operated with the “internal” master-clock oscillator. In the latter mode, the camera generates a pixel clock frequency of 10 MHz.

If the master-clock signal comes from an external source it must be assured that the utilised frequency is 2 times the desired pixel clock frequency. For example, if a 5 MHz pixel clock frequency is desired, the frame grabber must deliver a frequency of 10 MHz (max. 20 MHz).

The desired master-clock is selected via the MODE input at the interface.

Low \Rightarrow external master-clock

Frame grabber supplies MCLK signal

High \Rightarrow internal master-clock

Camera generates 10 MHz PVAL

Default Setting: If the MODE input at the interface is not utilised, the camera automatically selects the internal clock!

9 Connecting an Incremental Encoder Directly to the Camera

The UNILINE-2048 is designed to allow for direct connection of an incremental encoder to the camera. The encoder is provided with +5 V supply power from the camera via a 500 mA fuse. The fuse is located on the main PCB inside the camera.

After inserting the plug from the encoder into the 5-pin socket, camera controller logic is automatically switched to the internal integration timer. **It is absolutely essential to bridge pin 4 (Set_Ink) to pin 5 (0VD) in the 5-pin socket.** Switching only occurs if pin 4 is connected to 0VD. The EXSYNC control signals which are generally used by the grabber to control the camera are disabled in this operating mode.

Symmetric signals from the incremental encoder (RS 422) are terminated by the camera with 100 Ω terminating resistors, and are asymmetrically integrated into the camera controls with RS 422 receivers via a prescaler.

If the arrow at the "INCREMENTAL DIVIDER" code switch is set, for example, to "0", **each** negative pulse from the incremental encoder activates an integration and read-out phase. If the switch is set to "5", a new line would only be initialised for **each 6th** negative edge. This means that the scanning density to which the test sample is subjected can be influenced directly at the camera by means of the integrated prescaler.

Desired integration time can be selected with the "INTEGRATION TIMER" code switch. For example, if the arrow is set to "1", integration time is 150 μ s.

In order to assure reliable operation, trigger pulses from the incremental encoder must be separated by an interval of at least:

"selected integration time plus 8 μ s"

However, the fastest re-trigger time amounts to time required to read out 2048 active pixels and 42 inactive pixels at a pixel clock frequency of 10 MHz:

$$(2048 + 42) \times 100 \text{ ns} + 8\mu\text{s} = 217 \mu\text{s}$$

If re-triggering takes place earlier, timing is no longer coordinated, resulting in malfunctions during data transmission to the frame grabber.

10 Code Switch Tables

10.1 Prescaler for the Incremental Encoder

Code Switch Table
Prescaler for Incremental Encoder

Arrow Position	Scale Factor	Arrow Position	Scale Factor
0	1	8	9
1	2	9	10
2	3	A	11
3	4	B	12
4	5	C	13
5	6	D	14
6	7	E	15
7	8	F	16

10.2 Integration Timer in the Incremental Encoder Mode

Code Switch Table
Integration Timer

Arrow Position	Integration Time	Arrow Position	Integration Time
0	100 μ s	5	760 μ s
1	150 μ s	6	1.14 ms
2	225 μ s	7	1.7 ms
3	337 μ s	8	2.25 ms
4	506 μ s	9	3.82 ms

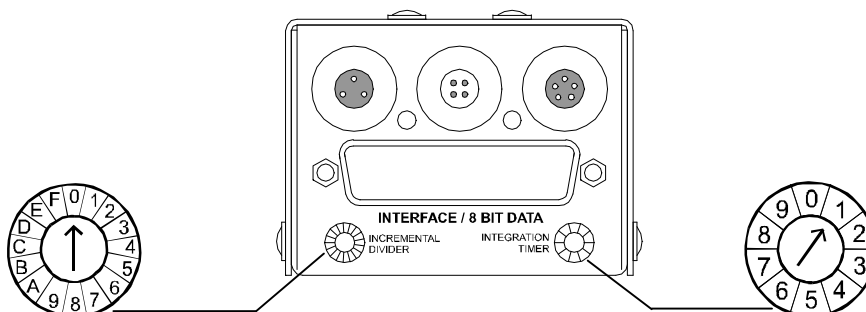

11 Connector Cable for Incremental Encoder

The following example illustrates the connection of a Heidenhain incremental encoder to the UNILINE-2048.

The blank end of the cable which has been prefabricated at the camera end (OPTI-SENS part no. 50.03.05) is soldered to the 12-pin Heidenhain round plug according to the following wiring plan.

Attention: Bridges must be soldered into the Heidenhain plug from pin 2 (white) to pin 12, and from pin 11 (grey) to pin 10 (blue).

UNILINE-2048			Incremental Encoder		
Pin	Colour	Signal	Colour	Pin	
1	white	+5 VD	white	2	plus bridge to pin 12
2	brown	- UA 1	brown	6	
3	black	+ UA 1	black	5	
4	blue	Set_Ink	blue	10	
5	grey	OVD	grey	11	plus bridge to pin 10
Housing	shield		shield	Housing	

12 Connecting a Frame-Start Initiator Directly to the Camera

Various initiators can be connected directly to the UNILINE-2048. For example, an NPN or a PNP inductive proximity switch can be directly connected with the help of prefabricated industrial cables of various length.

The initiator is provided with +12 V supply power from the camera via a 350 mA fuse. The fuse is located on the main PCB inside the camera.

From an electrical standpoint, the initiator does not cause triggering at the camera's electronics. The asymmetrical initiator signal is simply converted to a symmetrical RS 644 LVDS signal, and is applied to the interface data plug. This simplifies system wiring because the frame-start signal, as well as data and control signals to the frame grabber, are all transmitted via the same cable.

13 Gain Control and Gamma Function

Three different gain settings and gamma correction can be programmed at the UNILINE-2048 with two control bits. The control bits are TTL compatible inputs at the camera interface plug.

As a rule, frame grabbers are equipped with programmable I/O channels at the camera interface, by means of which gain control can be conveniently implemented for the camera.

The corresponding bit constellations are provided in the following truth table.

Default Setting: If the gain control inputs at the interface are not utilised, the camera automatically selects a gain setting of 4!

Function	Bit 0 (pin 21)	Bit 1 (pin 32)
GAMMA	0	0
GAIN = 1	1	0
GAIN = 2	0	1
GAIN = 4	1	1

Gain Truth Table

14 Line Scanning Camera Time Graph

14.1 Controlling the Camera via the Frame Grabber Interface

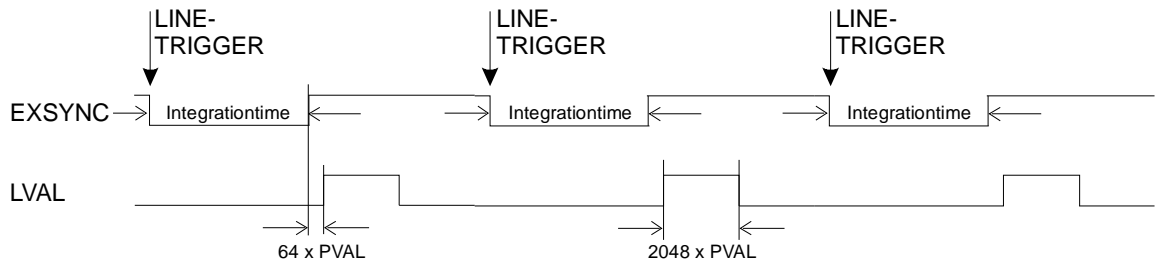

Line starts are triggered by the frame grabber with the falling edge of the EXSYNC signal. Now the programmable integration time runs and in the end of the programmable time, the rising edge of the EXSYNC signal is set. After an internal camera-specific delay of $64 \times \text{PVAL}$, the line valid signal shifts to high, where it remains for $2048 \times \text{PVAL}$.

14.2 Free-Running Operation

The UniLine-2048 turns automatically to the free-running mode when until 420 ms no edges detected on the EXSYNC input. It doesn't matter what state (high or low) the grabber gives out.

Alternatively, the EXSYNC input of the camera can be left open. In this case the camera is automatically switched to the free-running mode. Camera generated scanning rates are then dependent upon the BCD code switch position for the integration timer. Integration times for the free-running mode are indicated in the table included in chapter 14.3. Valid pixel data are indicated with the line valid signal (LVAL) in high state. Pixel data transfer takes place with the pixel valid signal (PVAL). Data exchange takes place at the interface with a delay of 18 ns after the positive edge. Data can be reliably transferred with the negative edge.

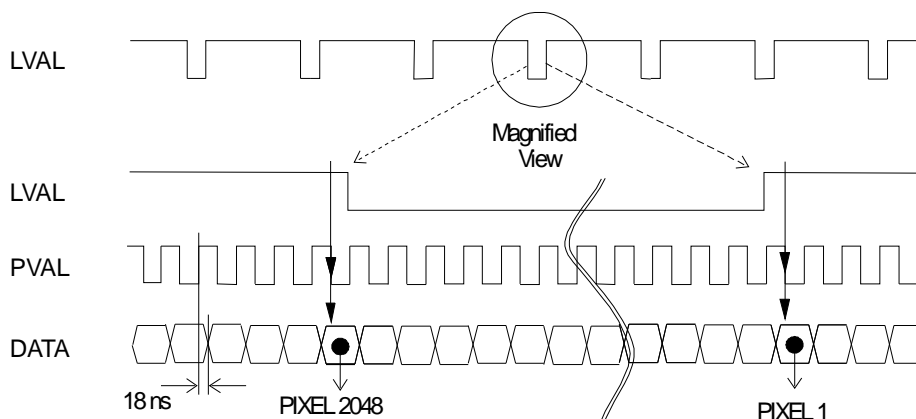

14.3 Integration Time Table for Free-Running Mode

If the UNILINE-2048 is not controlled via the EXSYNC input, and if no incremental encoder has been connected, the camera is switched automatically to the free-running mode.

Integrating time for this operating mode is selected with the "INTEGRATION TIMER" code switch. For example, if the arrow is set to the "0" position, the camera generates a maximum line frequency of 4.7 kHz.

The pixel clock (PCLK) always runs at 10 MHz in this operating mode. As a result, the line valid high state (LVAL) read-out phase always has a duration of 205 μ s, and low state is the remaining time as shown in the table (in this case 212 minus 205).

Arrow Position	Integration Time	Line Frequency
0	212 μ s	4.7 kHz
1	362 μ s	2.7 kHz
2	437 μ s	2.3 kHz
3	549 μ s	1.8 kHz
4	718 μ s	1.4 kHz
5	972 μ s	1.0 kHz
6	1.35 ms	740 Hz
7	1.91 ms	523 Hz
8	2.46 ms	406 Hz
9	4.03 ms	248 Hz

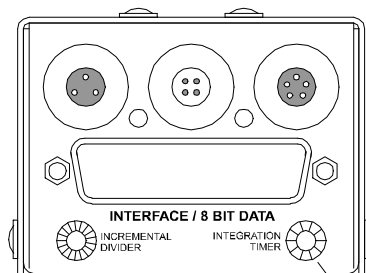

Integration Time
Code Switch

15 Connector Pin Assignments

15.1 Frame-Start, Supply Power and Incremental Encoder Connector Sockets

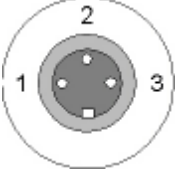
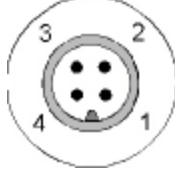
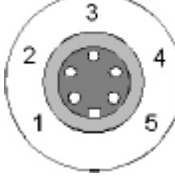
Connector Socket for Frame-Start Initiator			Connector Socket for Supply Power			Connector Socket for Incremental Encoder		
								
Pin	Signal	IN/OUT	Pin	Signal	IN/OUT	Pin	Signal	IN/OUT
1	0 V	O	1	+12V	I	1	+5 V	O
2	Initiator Signal	I	2	+12V	I	2	-Ua1	I
3	+12 V	O	3	0V	I	3	+Ua1	I
			4	0V	I	4	Set_Ink	I
						5	0 V	O

15.2 Interface, HD 44 Female – Signals Listed in Pairs

Pin	Signal	Pin	Signal
40	+ D0	20	OVD
39	- D0	36	+ frame trigger
12	+ D1	35	- frame trigger
11	- D1	34	- MCLK
27	+ D2	33	+ MCLK
26	- D2	4	+ MCLK mode - int / ext
42	+ D3	3	- MCLK mode - int / ext
41	- D3	19	+ EXSYNC
14	+ D4	18	- EXSYNC
13	- D4	2	+ Future use
29	+ D5	1	- Future use
28	- D5	21	bit gain 0 TTL
44	+ D6	32	bit gain 1 TTL
43	- D6	17	NC
15	+ D7	16	NC
30	- D7	37	NC
10	+ LVAL	38	NC
9	- LVAL	31	NC
25	+ PVAL	8	+12 V supply power
24	- PVAL	23	+12 V supply power
6	OVD	7	0 V supply power
5	OVD	22	0 V supply power

15.3 Interface, HD 44 Female – Signals Listed According to Pin No., Ascending

Pin	Signal	Pin	Signal
1	- Future use	23	+12 V power supply
2	+ Future use	24	- PVAL
3	- MCLK mode - int / ext	25	+ PVAL
4	+ MCLK mode - int / ext	26	- D2
5	OVD	27	+ D2
6	OVD	28	- D5
7	0 V power supply	29	+ D5
8	+12 V power supply	30	- D7
9	- LVAL	31	NC
10	+ LVAL	32	bit gain 1 TTL
11	- D1	33	+ MCLK
12	+ D1	34	- MCLK
13	- D4	35	- frame trigger
14	+ D4	36	+ frame trigger
15	+ D7	37	NC
16	NC	38	NC
17	NC	39	- D0
18	- EXSYNC	40	+ D0
19	+ EXSYNC	41	- D3
20	OVD	42	+ D3
21	bit gain 0 TTL	43	- D6
22	0 V power supply	44	+ D6

16 Camera Dimensions and Mounting

When mounting the camera, it must be assured that it is electrically isolated. This means that the camera housing may be not electrically connected to the machine. The camera is grounded via the connector cable from the frame grabber (PC) to the camera. This prevents interference caused by ground loops which may significantly impair signal quality.

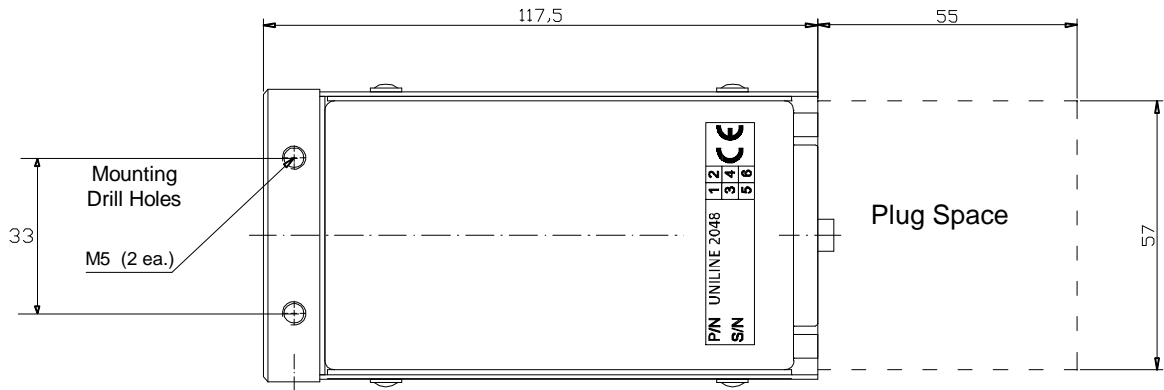

L1-L2-D, see chapter 7.1

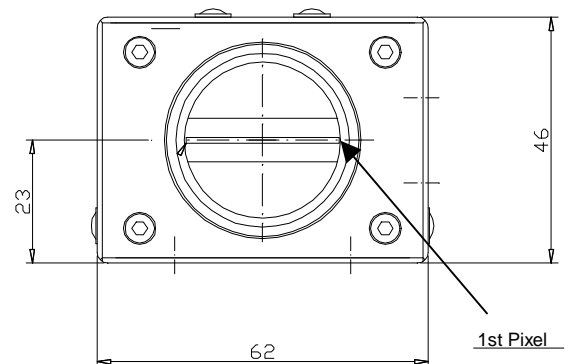
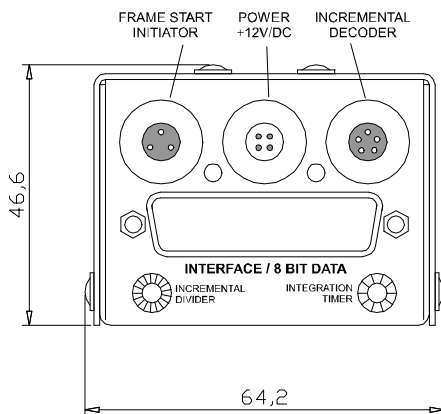
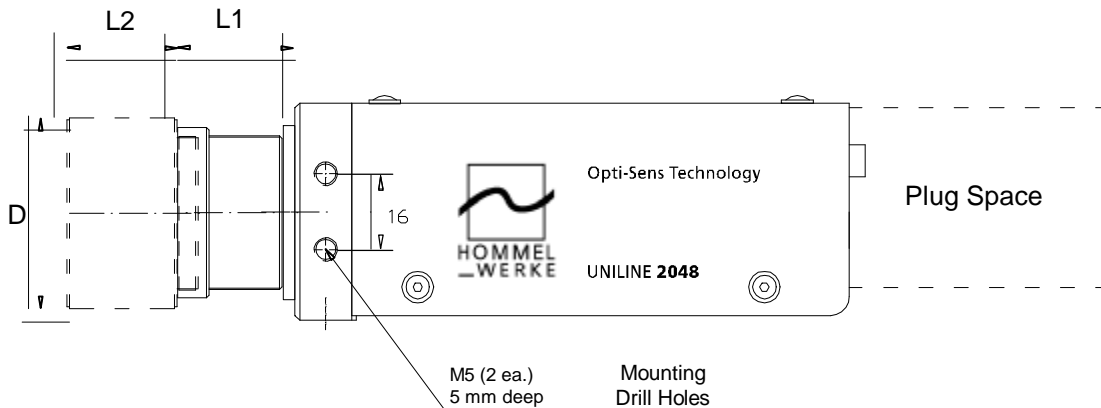

17 Technical Data

Sensor		Timing	
Pixel geometry	14 μm x 14 μm	Pixel frequency	max. 10 Mhz
Number of pixels	2048	Line frequency, free-running	max. 4.70 KHz
Active length of sensor line	28.67 mm	External start frequency	max. 4.60 KHz
Sensitivity	40 V/(lx*s)		

Electronics

Inputs HD SUB 44	Selection MCLK INT / EXT	RS 644 LVDS
	Static low corresponds to	Master clock at grabber active
	Static high corresponds to	Master clock at camera active
	External Master Clock (MCLK)	RS 644 LVDS
Optional	External Line Start (EXSYNC)	RS 644 LVDS
	Falling edge triggering	Line start
	Low state corresponds to	Integration time
	Shutter (integration control)	RS 644 LVDS
Inputs 3-pin initiator socket	HighIntegration time	
	Low	Pixel reset
	Gain Control	2 TTL control bits
	Frame Start	Low ~ 0.5 V, high ~ +12 V
5-pin incremental socket	Line Start via Incremental Encoder	RS 644 or RS 422
	+5 V supplied to encoder	
4-pin power supply socket	Power Supply	+12 V DC \pm 10%, ~ 300 mA
Outputs HD SUB 44	PIXEL VALID (PVAL)	RS 644 LVDS
	LINE VALID (LVAL)	RS 644 LVDS
	VIDEO Data, 8 BIT	RS 644 LVDS
	FRAME START	RS 644 LVDS
Power Consumption	Including supply power for incremental encoder and initiator	3.6 W
Operating Temperature		0° C to 45° C
Max. Relative Humidity	No condensation allowed	90%
Camera Weight , without lens	420 gr.	

Lens	Lens Mount	M39x1/26" or M32.5x0.5
------	------------	------------------------

Subject to change without notice 03 / 2002

18 Maintenance

Glass surfaces at the lenses and line sensor may neither be touched by the hands, nor come into contact with any other objects.

Dusty glass surfaces are best cleaned with dry, compressed air. If dust particles adhere stubbornly due to electrostatic charging, the use of ionised air is recommended.

Soiled glass surfaces can be cleaned with a cotton swab wetted with ethyl alcohol.

Caution: Do not scratch glass surfaces!

When the camera is not in use, it should be stored in an area which is protected from dust and contamination.

If excessive temperature differences occur as a result of moving the camera from one location to another, the camera and its accessories should be pre-warmed or pre-cooled in order to prevent the formation of condensation on glass surfaces.

19 Guarantee and Guarantee Conditions

- r No guarantee claims can be honoured if the camera has been opened.
- r The camera may only be screw-mounted with the help of the adapter thread.
- r Cables may only be connected or disconnected when the system is switched off.
- r Cables may not be kinked.

20 EC Declaration of Conformity

Document no. / month/year **031 / CEUNILINE-2048 / 10/2000**

Manufacturer
Address

Opti-Sens Technology

August-Borsig-Str. 13
78467 Konstanz

Product Designation: **Monochrome CCD Line Scanning Camera**
Typ: **UniLine-2048**

The designated product is in compliance with the stipulations set forth in the following European directives:

r RL73/23/EWG Low-voltage directive

r RL89/336/EWG EMC

Application of CE mark 10/2000

Issued by: see Manufacturer

Place, date Konstanz, Germany, 26 October, 2000

Hubert Keller
Legally binding signature

- r This declaration does not imply the guarantee of any characteristics.
- r Safety precautions in the included product documentation must be observed.